

N5186A MXG

Vector Signal Generator

Introduction

This data sheet provides key features and specifications for the N5186A MXG vector signal generator.



Table of Contents

Definitions and Conditions	3
Frequency	4
Frequency Reference.....	5
Output Power	6
Spectral Purity.....	12
Pulse Modulation (Option PMR)	16
Analog Modulation	18
Vector Modulation Specifications	22
Internal Baseband Generator (Options BxX / Rxx).....	24
Multi-Instrument Synchronization (Option SNC).....	26
Error Vector Magnitude (EVM).....	27
Distortion Performance (ACPR).....	28
Inputs and Outputs.....	30
Remote Programming	31
General Specifications	31
KeysightCare Coverage	33
Related Literature.....	34

Definitions and Conditions

Specifications represent warranted performance of a calibrated instrument that has been stored for a minimum of 2 hours within the operating temperature of 0 to 55 °C, unless otherwise stated, and after a 45 minute warm-up period. The specifications include measurement uncertainty. Data represented in this document are specifications unless otherwise noted.

Typical (typ) describes additional product performance information that is not covered by the product warranty. It is performance beyond specifications that 80 percent of the units exhibit with a 90 percent confidence level at room temperature (approximately 25 °C). Typical performance does not include measurement uncertainty.

Nominal (nom) values indicate the expected mean or average performance, or an attribute whose performance is by design, such as the 50 ohm connector. This data is not warranted and is measured at room temperature (approximately 25 °C).

Measured (meas) describes an attribute measured during the design phase for purposes of communicating expected performance, such as amplitude drift vs. time. This data is not warranted and is measured at room temperature (approximately 25 °C).

Frequency

Frequency options

Option	CW frequency range
N5186A-503	9 kHz to 3 GHz
N5186A-506	9 kHz to 6 GHz
N5186A-508	9 kHz to 8.5 GHz

Frequency resolution

CW	0.00001 Hz
----	------------

Phase adjustments

Adjustable in nominal 0.1° increments

Relative phase adjustments¹ (Option PCH and SNC)

Relative phase offset range	± 180°
Relative phase offset resolution	0.001°
Relative phase repeatability	0.0001° (nom) ²

Frequency switching speed^{3, 4}, () = typical

	Standard	Option UNZ
CW mode		
SCPI mode	(≤ 8 ms)	(≤ 8 ms)
Step/ list mode	(≤ 5 ms)	≤ 900 us (≤ 800 us)
Digital modulation		
SCPI mode	(≤11 ms)	(≤11 ms)
Step/ list mode	(≤ 5 ms)	≤ 900 us (≤ 800 us)

¹ Channel 1 relative to Channel 2, for example.

² When tuning from f1 to f2 and back to f1.

³ Time from receipt of SCPI command or trigger signal to within 0.1 ppm of final frequency or within 100 Hz, whichever is greater.

⁴ Specifications apply to serial numbers ≥ MY/US6433xxxx and when the instrument screen is disabled.

Frequency Reference

Frequency resolution

Internal time base reference oscillator aging rate ⁵	< $\pm 30 \times 10^{-9}$ /year after 30 days < $\pm 0.5 \times 10^{-9}$ /day after 30 days
Initial achievable calibration accuracy	$\pm 4 \times 10^{-8}$ or ± 40 ppb
Adjustment resolution	< 1.3×10^{-11}
Temperature effects	< $\pm 1 \times 10^{-8}$, nominal
Line voltage effects	< $\pm 1 \times 10^{-9}$ for $\pm 5\%$ change, nominal

Reference output

Frequency	10 MHz or 100 MHz, user selectable
Amplitude	$\geq +6$ dBm, nominal into 50 Ω load at 10 MHz reference output $\geq +8$ dBm, nominal into 50 Ω load at 100 MHz reference output

External reference input

Input frequency, standard	10 MHz
Input frequency, Option 1ER	1 MHz to 110 MHz (in multiples of 0.1 Hz)
Stability	Follows stability of external reference input signal
Lock range	± 1 ppm
Amplitude	-3 dBm to +20 dBm, nominal
Impedance	50 Ω , nominal
Waveform	Sine or square

Sweep modes (frequency and amplitude)

Operating modes	Step sweep	Equally spaced frequency and amplitude or logarithmically spaced frequency steps
	List sweep	Arbitrary list of frequency and amplitude steps. Simultaneously sweep waveforms with N5186A.
Sweep range	Within instrument frequency range	
Dwell time	100 μ s to 100 s	
Number of points	Step sweep	2 to 65535
	List sweep	1 to 3201
Step change	Linear or logarithmic	
Triggering	Free run, trigger key, global trigger, external, timer, bus (GPIB, LAN, USB)	

⁵ Not verified by Keysight N78000B ETMS Calibration and Adjustments Software. Daily aging rate may be verified as a supplementary chargeable service, on request.

Output Power

Output parameters

Settable range	+20 to -135 dBm (std) +30 to -135 dBm (Option 1EA)
Resolution	0.01 dB
Connector ⁶	Type N 50 Ω , nominal
Maximum reverse power	20 W, 50 VDC (nom)
Attenuator type	Electronic

Maximum output power, () = typical

Frequency range	Standard	Option 1EA
9 kHz to < 20 kHz	+1 dBm	+1 dBm (+4 dBm)
20 kHz to < 50 kHz	+7 dBm	+7 dBm (+10 dBm)
50 kHz to < 200 kHz	+12 dBm	+12 dBm (+14 dBm)
200 kHz to < 10 MHz	+15 dBm	+15 dBm (+19 dBm)
10 MHz to < 5 GHz	+18 dBm	+25 dBm (+26 dBm)
5 GHz to < 8 GHz	+18 dBm	+23 dBm (+25 dBm)
8 GHz to < 8.5 GHz	+18 dBm	+22 dBm (+24 dBm)

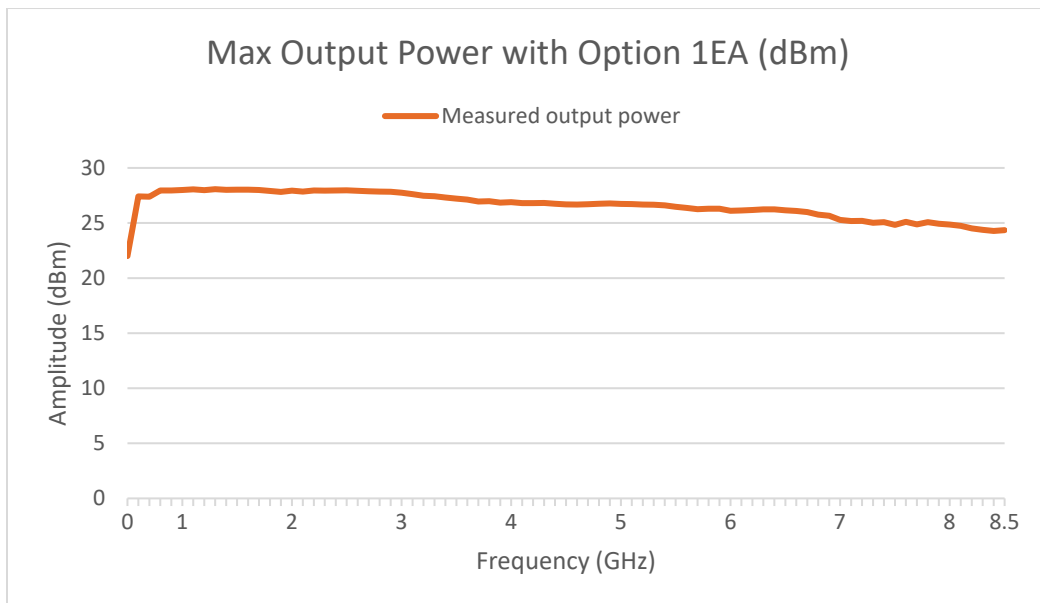

⁶ Connector type for configurations with Options 1EM, 001, 002, 003, and 004 is 3.5 mm.

Absolute level accuracy (CW) ^{7,8}, temperature range 20 to 30 °C, () = typical

Frequency range	+20 dBm to +15 dBm (option 1EA)	< +15 dBm to +5 dBm	< +5 dBm to -60 dBm	< -60 dBm to -95 dBm	< -95 dBm to -110 dBm	< -110 dBm to -130 dBm (option 1EQ)
9 kHz to < 100 kHz	-	-	± 3.1 dB (± 1.5 dB)	(± 2.7 dB)	-	-
100 kHz to 10 MHz	± 1.1 dB (± 0.5 dB)	± 0.8 dB (± 0.2 dB)	± 1.0 dB (± 0.5 dB)	± 1.5 dB (± 0.7 dB)	-	-
>10 MHz to < 270 MHz	± 2.3 dB (± 1.6 dB)	± 1.3 dB (± 0.6 dB)	± 1.2 dB (± 0.5 dB)	± 2.0 dB (± 1.2 dB)	± 2.7 dB (± 1.2 dB)	± 2.7 dB (± 1.2 dB)
270 MHz to < 800 MHz	± 0.9 dB (± 0.4 dB)	± 0.9 dB (± 0.3 dB)	± 0.8 dB (± 0.3 dB)	± 0.8 dB (± 0.3 dB)	± 0.9 dB (± 0.3 dB)	± 0.9 dB (± 0.3 dB)
800 MHz to < 5 GHz	± 0.8 dB (± 0.3 dB)	± 0.8 dB (± 0.3 dB)	± 0.8 dB (± 0.3 dB)	± 0.9 dB (± 0.3 dB)	± 1.3 dB (± 0.6 dB)	± 1.3 dB (± 0.6 dB)
5 GHz to < 7 GHz	± 1.0 dB (± 0.3 dB)	± 1.0 dB (± 0.3 dB)	± 1.0 dB (± 0.4 dB)	± 1.1 dB (± 0.5 dB)	± 1.5 dB (± 0.7 dB)	± 1.5 dB (± 0.7 dB)
7 GHz to 8.5 GHz	± 1.3 dB (± 0.5 dB)	± 1.2 dB (± 0.4 dB)	± 1.1 dB (± 0.5 dB)	± 1.4 dB (± 0.6 dB)	± 1.9 dB (± 0.8 dB)	± 1.9 dB (± 0.8 dB)

I/Q modulated level accuracy relative to CW, temperature range 20 to 30 °C, () = typical

Power level	< +15 dBm to +5 dBm	< +5 dBm to -40 dBm	< +15 dBm to +5 dBm	< +5 dBm to -20 dBm
Frequency range	W-CDMA 1 DPCH configuration		5G FR1 SCS60 100 MHz	
100 MHz to < 270 MHz	± 0.7 dB (± 0.3 dB)	± 0.7 dB (± 0.4 dB)	± 0.8 dB (± 0.5 dB)	± 0.8 dB (± 0.5 dB)
270 MHz to < 800 MHz	± 0.5 dB (± 0.3 dB)	± 0.7 dB (± 0.4 dB)	± 0.7 dB (± 0.4 dB)	± 0.5 dB (± 0.3 dB)
800 MHz to < 7 GHz	± 0.5 dB (± 0.3 dB)	± 0.5 dB (± 0.2 dB)	± 0.7 dB (± 0.4 dB)	± 0.4 dB (± 0.2 dB)
7 GHz to 8.5 GHz	± 0.7 dB (± 0.4 dB)	± 0.5 dB (± 0.2 dB)	± 0.5 dB (± 0.3 dB)	± 0.3 dB (± 0.2 dB)

⁷ Specifications apply for power alignments > 800 MHz.

⁸ Performance operating below 20 kHz frequency is not warranted if the power level is set below -85 dBm.

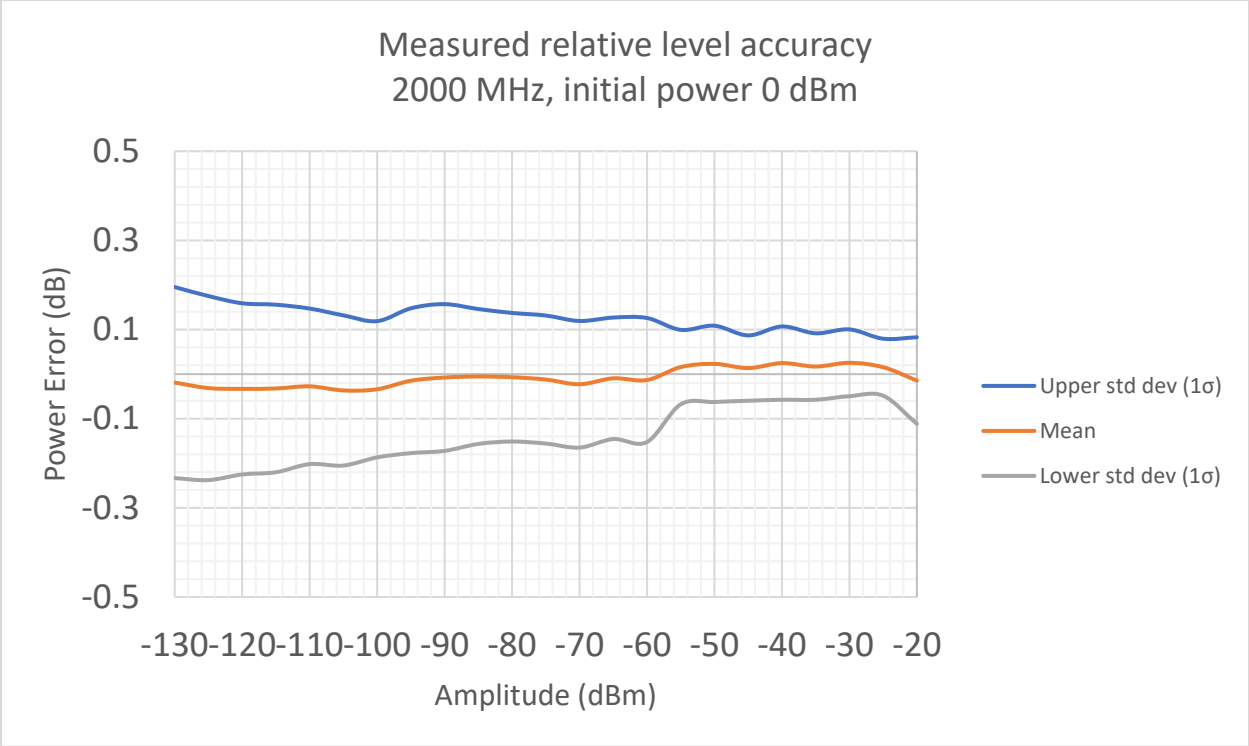

Relative level accuracy measures the accuracy of a step change from any power level to any other power level. This is useful for large changes (such as 5 dB steps).

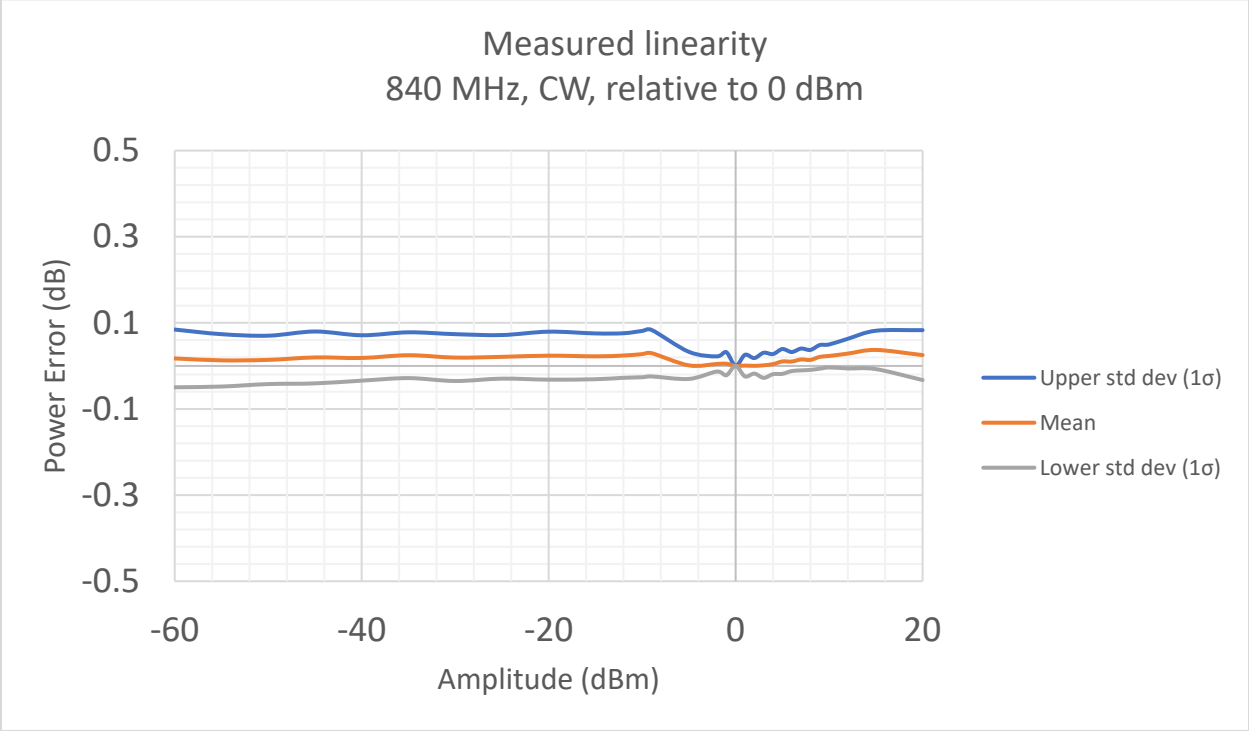

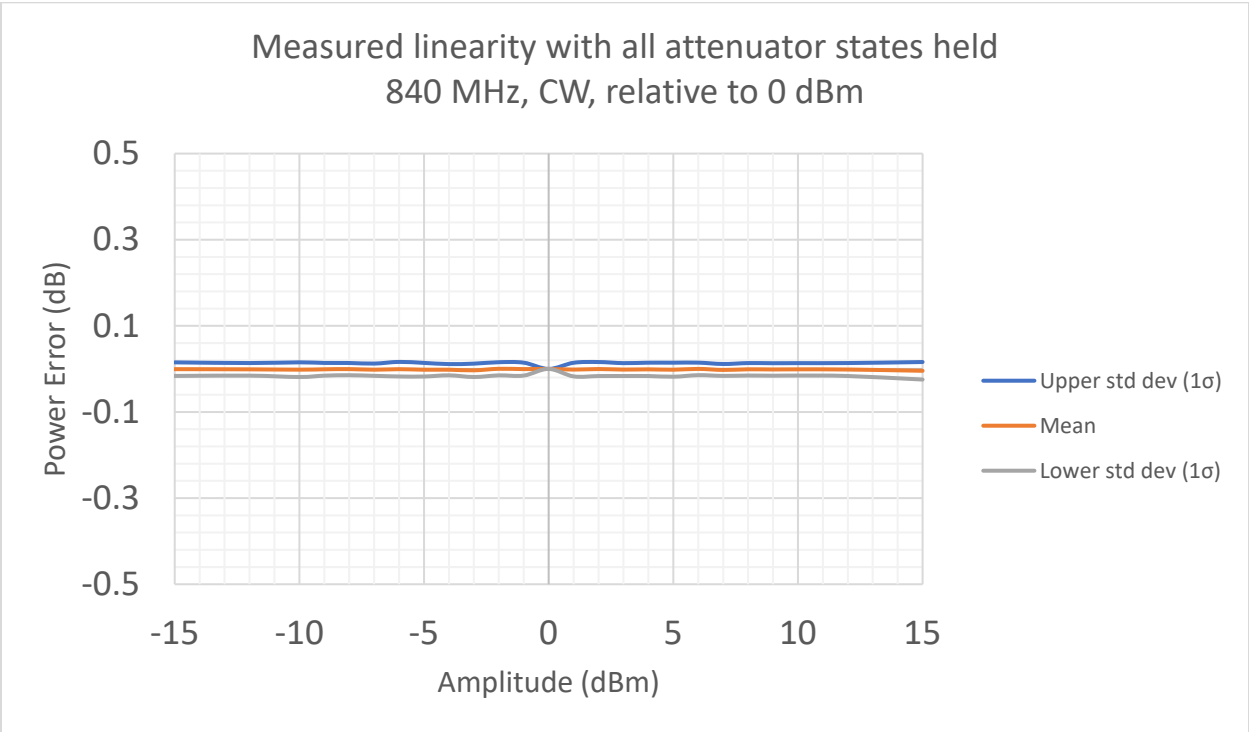
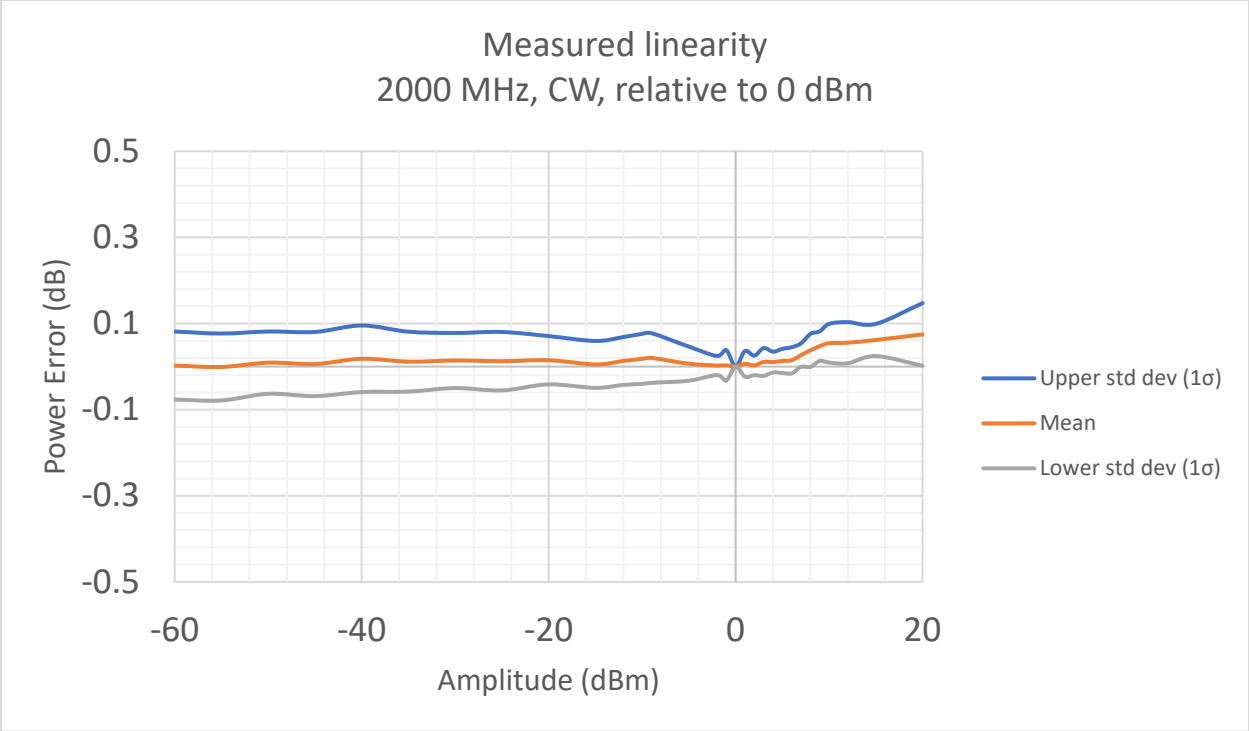

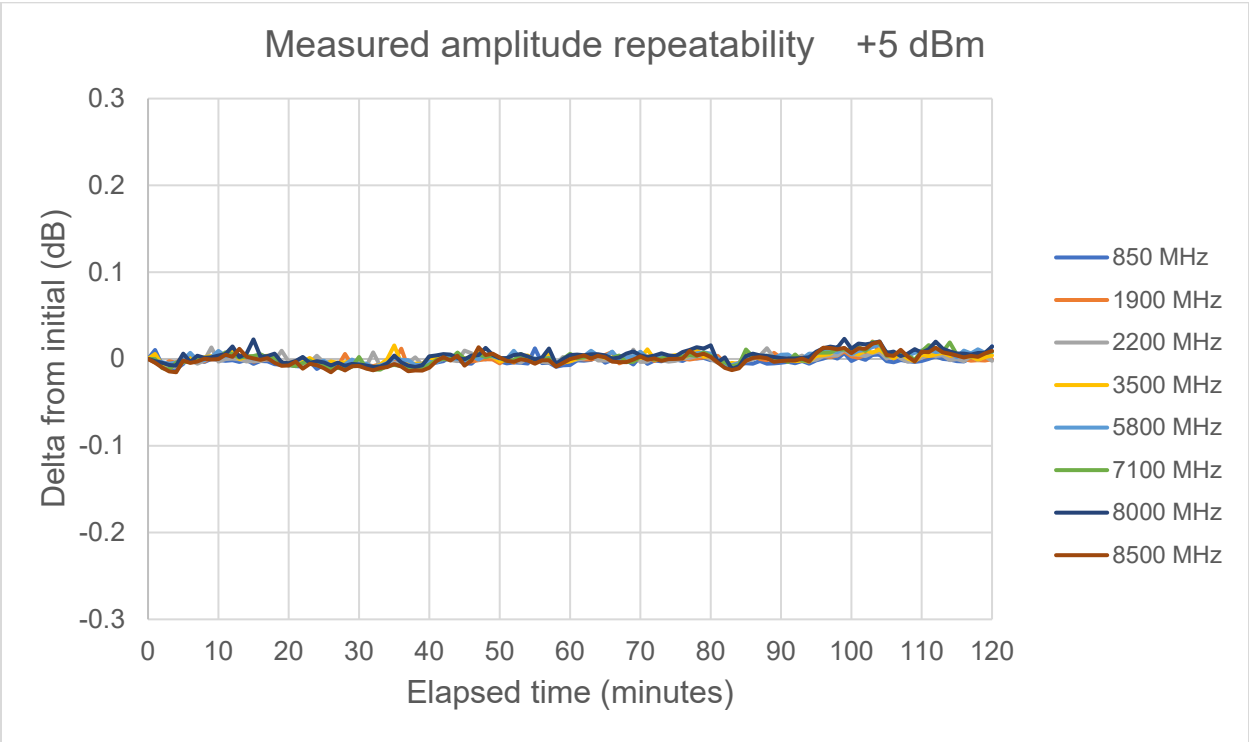
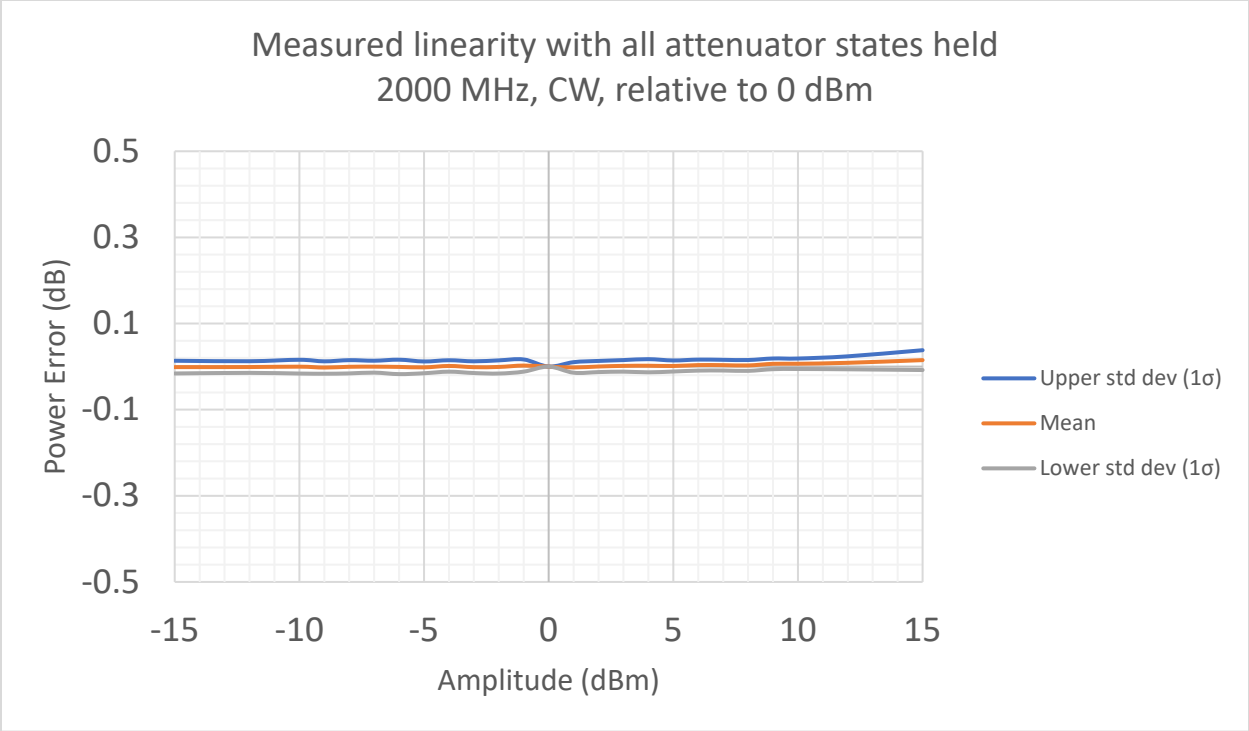

Repeatability measures the ability of the instrument to return a given power setting after a random excursion to any other frequency and power setting. It should not be confused with absolute level accuracy.

VSWR, measured

Frequency range	Option UNM	Option 1EM
30 kHz to < 60 kHz	< 3.0:1	< 3.0:1
60 kHz to < 800 kHz	< 2.0:1	< 2.0:1
800 kHz to < 1 MHz	< 1.7:1	< 1.7:1
1 MHz to < 10 MHz	< 1.25:1	< 1.25:1
10 MHz to < 30 MHz	< 2.1:1	< 2.1:1
30 MHz to < 6.8 GHz	< 1.5:1	< 1.5:1
6.8 GHz to 8.5 GHz	< 1.9:1	< 1.7:1

Amplitude switching speed ^{9, 10}, () = typical

	Standard	Option UNZ
CW mode		
SCPI mode	(≤ 8 ms)	(≤ 8 ms)
Step/ list mode	(≤ 5 ms)	≤ 500 us (≤ 400 us)
Digital modulation		
SCPI mode	(≤ 11 ms)	(≤ 11 ms)
Step/ list mode	(≤ 5 ms)	≤ 900 us (≤ 550 us)

Embedded Reflectometer (Option V08)

Embedded Reflectometer (Option V08; Requires E7653APPC)

The embedded reflectometer enables a variety of measurements & corrections over a user specified frequency span including:

- DUT match (S11) characterization
- Fixture characterization for fixtures with a coaxial connection using traditional vector network analyzer ECal kits.

After characterization of fixtures and/or DUT match, the N5186A can apply these corrections in real-time as you tune the signal generator. See [N5186A MXG Vector Signal Generator Measurement Guide](#) for more details.

Frequency range	10 MHz to 8.5 GHz
S-parameter measurement power	-15 dB (nom)
Maximum input level	See Maximum reverse power for damage levels
Compatible ECal (electronic calibration) kits	N7550A, N7551A, N7552A, N7553A, N7554A, N7555A, N4690D, N4691D, N4692D, N4693D, N4694D

⁹ Time from receipt of SCPI command or trigger signal to amplitude settled within 0.2 dB.

¹⁰ Specifications apply to serial numbers ≥ MY/US6433xxxx and when the instrument screen is disabled.

Spectral Purity

Harmonics (CW), () = typical

Frequency range	≤ +10 dBm	≤ +12 dBm
9 kHz to 100 kHz	(<-30 dBc) ¹¹	n/a
> 100 kHz to 3 GHz	<-35 dBc (-41 dBc)	<-33 dBc (-39 dBc)
> 3 GHz to 4.25 GHz	<-30 dBc (-34 dBc)	(<-32 dBc)
> 4.25 GHz to 8.5 GHz	(<-34 dBc)	(<-32 dBc)

Non-harmonics (CW), > 10 kHz offset, +10 dBm, temperature range 20 to 30 °C, () = typical

Frequency range	Standard (+10 dBm)	Option EP3 / EP4
9 kHz to < 15 MHz	-52 dBc	-52 dBc (-59 dBc)
15 MHz to < 30 MHz	-60 dBc	-60 dBc (-68 dBc)
30 MHz to < 8.5 GHz	-75 dBc	-80 dBc

Subharmonics

None

Fixed spurs, +10 dBm

Frequency range	
300 MHz	-77 dBc
DAC spur (19.2 GHz – 2 _{f_{out}})	-67 dBc
DAC spur (3 _{f_{out}} –19.2 GHz)	-69 dBc

Absolute SSB phase noise (CW in enhanced SNR mode at +10 dBm) (dBc/Hz), Standard, temperature range 20 to 30 °C, () = typical

Frequency	1 Hz	10 Hz	100 Hz	1 kHz	10 kHz	100 kHz	1 MHz	10 MHz	100 MHz
100 MHz	(-89)	-103 (-110)	-120 (-126)	-140 (-146)	-143 (-148)	-143 (-148)	-141 (-149)	-141 (-148)	-
500 MHz	(-76)	-89 (-96)	-106 (-113)	-130 (-135)	-136 (-140)	-136 (-140)	-150 (-157)	-150 (-157)	(-157)
1 GHz	(-70)	-84 (-90)	-99 (-106)	-124 (-129)	-129 (-134)	-129 (-134)	-150 (-157)	-150 (-158)	(-158)
2 GHz	(-64)	-77 (-84)	-93 (-100)	-117 (-123)	-123 (-128)	-123 (-127)	-146 (-154)	-150 (-158)	(-158)
3 GHz	(-60)	-74 (-80)	-89 (-96)	-114 (-120)	-119 (-124)	-119 (-124)	-144 (-152)	-152 (-158)	(-158)
4 GHz	(-59)	-71 (-77)	-87 (-94)	-112 (-117)	-116 (-122)	-116 (-121)	-141 (-150)	-151 (-157)	(-158)
6 GHz	(-55)	-68 (-74)	-84 (-90)	-108 (-114)	-113 (-118)	-113 (-118)	-137 (-146)	-149 (-155)	(-155)
8 GHz	(-53)	-66 (-72)	-82 (-88)	-105 (-111)	-111 (-116)	-110 (-115)	-134 (-144)	-146 (-153)	(-153)

¹¹ Measured at 0 dBm or maximum specified power, whichever is less.

Absolute SSB phase noise (CW in enhanced SNR mode at +10 dBm) (dBc/Hz), Option EP3, temperature range 20 to 30 °C, () = typical

Frequency	1 Hz	10 Hz	100 Hz	1 kHz	10 kHz	100 kHz	1 MHz	10 MHz	100 MHz
100 MHz	(-90)	-103 (-110)	-120 (-126)	-140 (-146)	-143 (-149)	-143 (-149)	-141 (-149)	-141 (-148)	-
500 MHz	(-76)	-89 (-96)	-106 (-112)	-130 (-136)	-140 (-146)	-140 (-146)	-150 (-157)	-150 (-157)	(-157)
1 GHz	(-69)	-84 (-90)	-99 (-106)	-123 (-129)	-133 (-139)	-133 (-139)	-149 (-157)	-150 (-158)	(-158)
2 GHz	(-64)	-78 (-84)	-93 (-99)	-117 (-123)	-126 (-132)	-127 (-132)	-146 (-154)	-150 (-158)	(-158)
3 GHz	(-60)	-74 (-80)	-89 (-96)	-114 (-120)	-123 (-129)	-123 (-129)	-144 (-152)	-152 (-158)	(-158)
4 GHz	(-58)	-72 (-78)	-87 (-93)	-111 (-117)	-119 (-125)	-121 (-126)	-141 (-150)	-150 (-157)	(-157)
6 GHz	(-55)	-68 (-74)	-84 (-91)	-107 (-114)	-117 (-123)	-117 (-123)	-137 (-146)	-149 (-155)	(-156)
8 GHz	(-53)	-66 (-72)	-81 (-88)	-104 (-111)	-115 (-120)	-115 (-120)	-134 (-144)	-147 (-153)	(-153)

Absolute SSB phase noise (CW in enhanced SNR mode at +10 dBm) (dBc/Hz), Option EP4, temperature range 20 to 30 °C, () = typical

Frequency	1 Hz	10 Hz	100 Hz	1 kHz	10 kHz	100 kHz	1 MHz	10 MHz	100 MHz
100 MHz	(-92)	-111 (-118)	-121 (-127)	-139 (-146)	-148 (-152)	-148 (-153)	-146 (-153)	-145 (-152)	-
500 MHz	(-78)	-95 (-104)	-106 (-113)	-131 (-138)	-144 (-151)	-149 (-154)	-150 (-157)	-151 (-157)	(-157)
1 GHz	(-71)	-88 (-96)	-100 (-107)	-125 (-132)	-141 (-146)	-146 (-150)	-149 (-157)	-151 (-158)	(-158)
2 GHz	(-65)	-83 (-92)	-93 (-101)	-120 (-127)	-135 (-141)	-139 (-144)	-149 (-155)	-151 (-158)	(-158)
3 GHz	(-63)	-80 (-88)	-89 (-97)	-117 (-123)	-133 (-138)	-136 (-141)	-145 (-153)	-151 (-158)	(-158)
4 GHz	(-60)	-78 (-86)	-86 (-94)	-114 (-121)	-130 (-136)	-132 (-138)	-143 (-151)	-151 (-157)	(-158)
6 GHz	(-56)	-73 (-81)	-84 (-91)	-111 (-118)	-128 (-133)	-130 (-135)	-140 (-148)	-149 (-156)	(-156)
8 GHz	(-53)	-70 (79)	-81 (-88)	-108 (-115)	-125 (-130)	-128 (-132)	-136 (-145)	-147 (-153)	(-154)

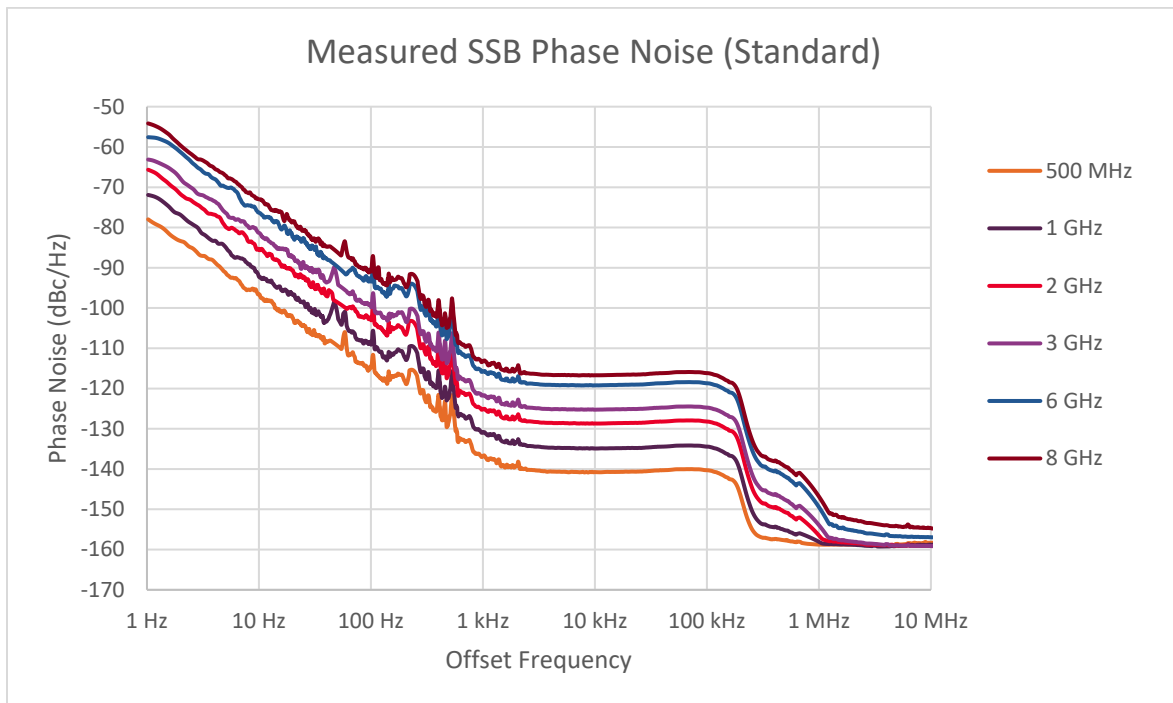

Measured SSB Phase Noise (Option EP3)

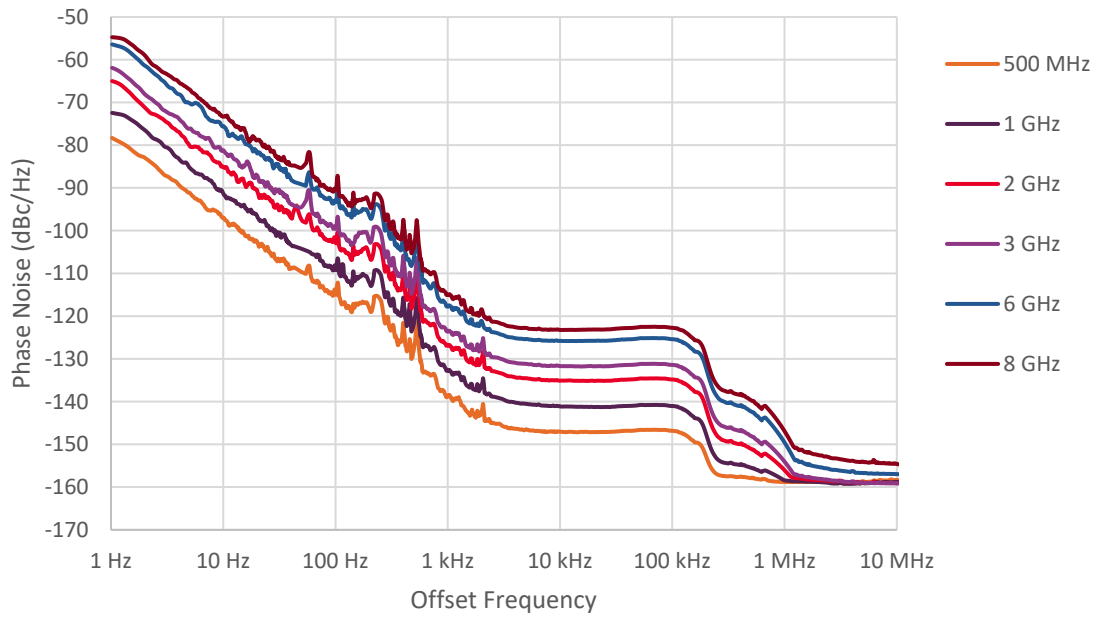

Measured SSB Phase Noise (Option EP4)

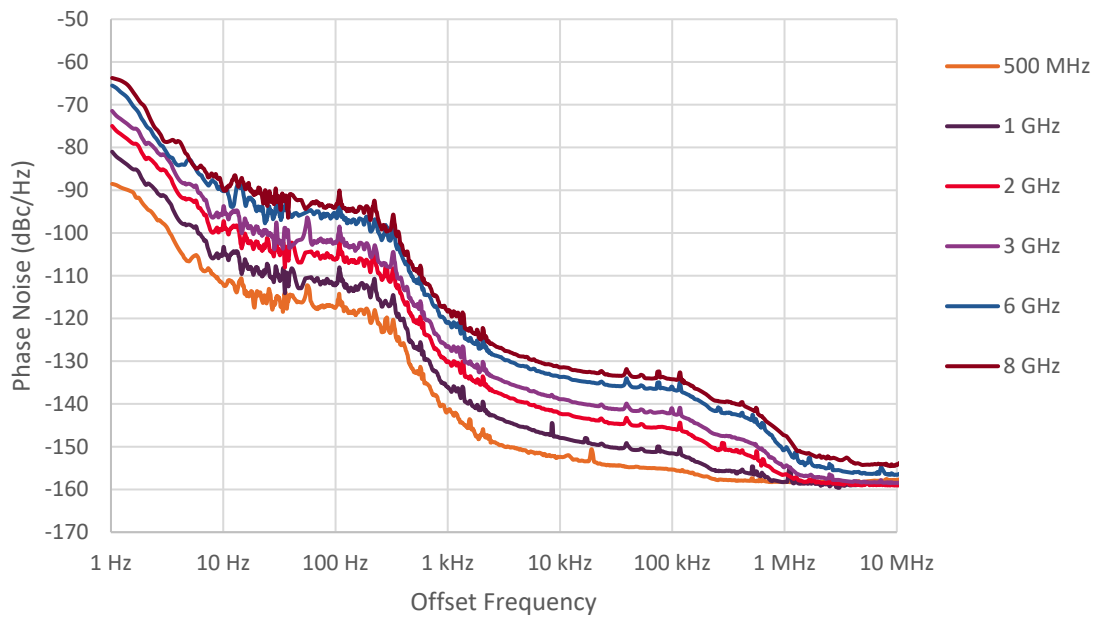

Jitter ¹², measured

Carrier frequency	RMS jitter			μ UI rms		
	Standard	Option EP3	Option EP4	Standard	Option EP3	Option EP4
155 MHz	30.8 fs	26.97 fs	26.83 fs	4.8	4.2	4.2
622 MHz	18.95 fs	12.8 fs	11.51 fs	11.8	8	7.2
2.488 GHz	16.14 fs	8.23 fs	6.17 fs	40.2	20.5	15.4

Secondary DDS tone generator (Option CW1)

Enables a secondary DDS tone generator that can reduce the 2nd harmonic tone. Compatible only with harmonic products of CW signals; not compatible with harmonic products of modulated signals.

Carrier settings

Carrier frequency range	9 kHz to 8.5 GHz
Carrier amplitude range	+10 to -50 dBm (nom)

Secondary DDS tone generator settings

Frequency range	9 kHz to 8.5 GHz
Amplitude range	-10 to -70 dBc (nom)
Phase range	-180° to +180° (nom)
Maximum tone improvement ¹³	Up to 15 dB (nom)

¹² Calculated from phase noise performance at +10 dBm (CW in enhanced SNR mode)

¹³ Phase setting of the secondary DDS tone generator varies depending on the phase of the 2nd harmonic tone.

Pulse Modulation (Option PMR)

Pulse modulation ^{14, 15, ()} = typical

On/off ratio	(105 dB)	
Rise/fall times	10 ns (8 ns)	
Minimum pulse width	20 ns	
Level accuracy (relative to CW)	< ± 1 dB (± 0.3 dB)	
Width compression	(± 5 ns)	
Video feed-through ¹⁶	(< 85 mV)	
External video delay	Internal ¹⁷	320 ns, nominal
	External	120 ns, nominal
RF delay	5 ns, nominal	
Pulse overshoot	(< 15%)	
Input level	High-level	0.575 V, nominal
	Low-level	0.425 V, nominal

T_d video delay (variable)
 T_w video pulse width (variable)
 T_p pulse period (variable)
 T_m RF delay
 T_{rf} RF pulse width
 T_f RF pulse fall time
 T_r RF pulse rise time
 V_{or} pulse overshoot
 V_f video feedthrough

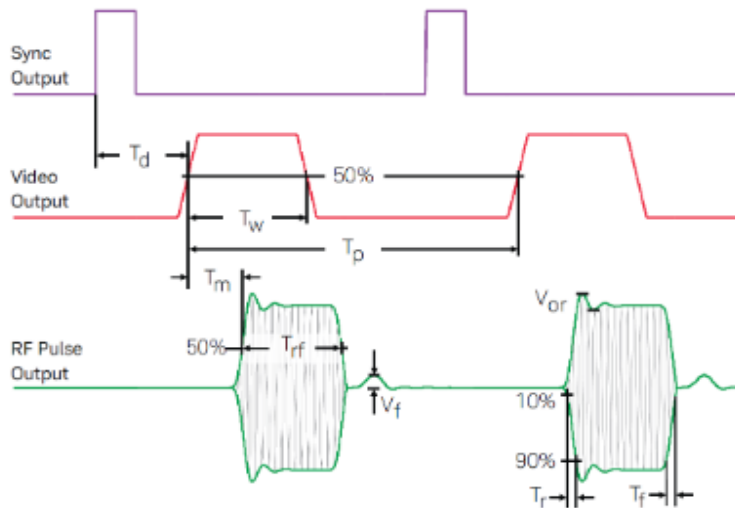

¹⁴ Specifications apply to center frequencies ≥ 100 MHz and powers set to ≥ -10 dBm. Operable down to 9 kHz.

¹⁵ Specifications apply to serial numbers \geq MY/US641xxxx.

¹⁶ Applies to power level $< +10$ dBm.

¹⁷ Applies to externally triggered internal pulse modulation.

Internal pulse generator (Option PMR)

Modes	Square, free run, triggered, adjustable doublet	
Square wave rate	0.1 Hz to 25 MHz	
Signal routing	Pulse trigger input	Pulse In
	Pulse sync output	Trigger 2
	Pulse video output	Trigger 1
Pulse period	30 ns to 42 s	
Pulse width	20 ns to (42 s – 10 ns)	
Resolution	10 ns	
Settable delay	Square	(-10 ns + 10 ns) to (5 s – 10 ns)
	Free run	(-42 s + 10 ns) to (42 s – 30 ns)
	Triggered	0 to (42 s – 30 ns)
Pulse doublets	1 st pulse delay	0 to (42 s – 30 ns)
	1 st pulse width	20 ns to (42 s – 10 ns)
	2 nd pulse delay	0 to (42 s – 30 ns)
	2 nd pulse width	20 ns to (42 s – 10 ns)

Analog Modulation

Frequency bands

Band #	Frequency range
1	9 kHz to < 10 MHz
2	10 MHz to < 8.5 GHz

Frequency modulation ¹⁸ (Option UNT)

		Internal	External
Max deviation		± 500 MHz (nom)	
Resolution		0.1% of deviation or 1 Hz, whichever is greater (nom)	
Deviation accuracy @ 1 kHz rate	Deviation ≤ 1 MHz (Deviation ≤ 5 MHz, typical)	< ± 1.5% of setting + 20Hz	< ± 1.5% of setting + 20 Hz, typical
	5 MHz < deviation ≤ 10 MHz	< ± 2% of setting + 20Hz, typical	< ± 2% of setting + 20 Hz, typical
Modulation frequency response @ 100 kHz deviation	0.5 dB bandwidth	DC/50 kHz to 3 MHz (nom)	
	1 dB bandwidth	DC/50 kHz to 10 MHz (nom)	
Carrier frequency accuracy		< ± 0.2% of set deviation (nom)	
Total harmonic distortion @ 1 kHz rate, 1 MHz deviation		< 0.4%	< 0.4%, typical

Phase modulation ¹⁹ (Option UNT)

		Internal	External
Max deviation		600MHz / rate or 12π, whichever is less (nom)	
Resolution		0.1% of deviation (nom)	
Frequency response, 3 rad deviation, 3 dB bandwidth		DC/50 kHz to 10 MHz (nom)	
Deviation accuracy @ 1 kHz rate		< ± 0.5% + 0.01 rad, typical	< ± 0.5% + 0.01 rad, typical
Total harmonic distortion @ 1 kHz rate, 1 rad deviation		< 0.2%, typical	

¹⁸ Specifications apply to serial numbers ≥ MY/US6433xxxx.

¹⁹ Specifications apply to serial numbers ≥ MY/US6433xxxx and when the RF amplitude is set 6 dB below the maximum specified power.

Amplitude modulation ^{18, 19} (Option UNT)

		Internal		External	
		Linear	Exponential	Linear	Exponential
Maximum depth		100% (nom)	40 dB (nom)	100% (nom)	40 dB (nom)
Depth resolution		0.1% (nom)	0.01 dB (nom)	0.1% (nom)	0.01 dB (nom)
Depth accuracy @ 1 kHz rate, ≤ 80% depth ^{20, 21}	f ≤ 3 GHz	< ± 1.5% of setting + 1% (0.5% of setting + 1%, typ)	< ± 1 dB (typ)	< ± 0.5% of setting + 1%, typ	< ± 1 dB (typ)
Total harmonic distortion @ 1 kHz rate	f < 5 MHz	30% depth	< 0.25% (typ)		
		80% depth	< 0.5% (typ)		
	5 MHz ≤ f < 2 GHz	30% depth	< 2%		< 2% (typ)
		80% depth	< 2%		
2 ≤ f < 3 GHz	30% depth	< 2% (typ)			
Frequency response, 30% depth, 1 dB bandwidth		DC/50 kHz to 10 MHz (nom)			

Simultaneous and composite modulation

Simultaneous modulation	All modulation types (I/Q, FM, AM, ΦM, and pulse modulation) may be simultaneously enabled except: FM and phase modulation cannot be combined and two modulation types cannot be simultaneously generated using the same modulation source; for example, the baseband generator, AM, and FM can run concurrently and all will modulate the output RF (this is useful for simulating signal impairments).					
Composite modulation	AM, FM, and ΦM each consist of two modulation paths which are summed internally for composite modulation; modulation can be any combination of internal or external sources					
	AM	FM	PM	Pulse	Internal I/Q	External I/Q
AM	X	X	X	X	X	n/a
FM	X	X	O	X	X	n/a
PM	X	O	X	X	X	n/a
Pulse	X	X	X	O	X	n/a
Internal I/Q	X	X	X	X	n/a	n/a
External I/Q	n/a	n/a	n/a	n/a	n/a	n/a
X = compatible			O = not compatible			

EXT1 & EXT2 external analog modulation inputs

Channel 1 only. Requires Option UNT.	
Modulation type	AM, FM, ΦM
Input amplitude	AM: -1 V for indicated depth, ±1 V range FM, ΦM: -1 V for indicated deviation, ±1 V range ±5 V damage levels
Input impedance	50 Ω, 600 Ω, 100 kΩ, selectable
Coupling	DC- and AC-coupling, selectable

²⁰ Specifications apply to power levels at -12 dBm and +10 dBm.

²¹ External exponential AM depth accuracy applies with a 1 VDC input signal.

Standard internal analog modulation source

(Single sine wave generator for use with AM, FM, phase modulation requires Option UNT or 303)	
Waveform	Sine, square, triangle, positive ramp, negative ramp
Rate range	0.1 Hz to 2 MHz (tunable to 3 MHz)
Resolution	0.1 Hz
Frequency accuracy	Same as RF reference source, nominal
LF output	-1V < (peak amplitude ± offset) < 5 V, nominal into 50 Ω. Channel 1 only.

Frequency parameters

Sine wave	0.01 Hz to 10 MHz
Triangle, square, ramp, pulse	0.01 Hz to 1 MHz (nom)
Noise BW	10 MHz (nom)
Resolution	0.01 Hz

Multifunction generator (option 303)

The multifunction generator option (Option 303) consists of seven waveform generators that can be set independently with up to five simultaneously using the composite modulation features in AM, FM, ΦM, and LF out.

Function generator 1	Sine, triangle, square, ramp, pulse
Function generator 2	Sine, triangle, square, ramp, pulse
Dual function generator	Sine, triangle, square, ramp, phase offset, and amplitude ratio for Tone 2 relative to Tone 1
Swept function generator	Sine, triangle, square, ramp Trigger: free run, trigger key, bus, external, internal, global trigger (option PCH)
Noise generator 1	Uniform, Gaussian
Noise generator 2	Uniform, Gaussian
DC	LF output only. -1 V to +5 V, nominal into 50 Ω

Avionics (E7641APPC)

VOR		
Bearing accuracy	± 0.1°	
Frequency accuracy	Same as RF reference source, nominal	
AM accuracy	30% depth	± 5% of setting
AM distortion	2%	
FM accuracy	480 Hz deviation	± 1.7 Hz
ILS: localizer and glide slope		
AM accuracy	40% depth ± 5% of setting	
AM distortion	2%	
Difference in depth of modulation (DDM) resolution	Localizer	0.0002
	Glide slope	0.0004
Difference in depth of modulation (DDM) accuracy	Localizer	± 0.0004 ± 5% of DDM ²²
	Glide slope	± 0.0008 ± 5% of DDM ²²

²² DDM must not be equal to 0.

Marker beacon		
Marker tone AM accuracy	95% depth	± 5% of setting + 1%
Marker tone AM distortion	95% depth	5%

I/Q based analog modulation (E7642APPC)

This section describes the functionality provided by E7642APPC PathWave Signal Generation for I/Q based amplitude modulation. External inputs are not supported.

Amplitude modulation		
Waveform	Sine, dual-sine, triangle, ramp up, ramp down, square	
AM rate	Sine	1 Hz to (maximum baseband bandwidth / 2) ²³
	All other waveforms	1 Hz to (maximum baseband bandwidth / 16) ^{Error!} Bookmark not defined.
AM depth	0 to 100%	
Frequency modulation		
Waveform	Sine, dual-sine, triangle, ramp up, ramp down, square	
AM rate	Sine	1 Hz to (maximum baseband bandwidth / 4) ^{Error!} Bookmark not defined.
	All other waveforms	1 Hz to (maximum baseband bandwidth / 16) ^{Error!} Bookmark not defined. ^{Error!} Bookmark not defined.
FM depth	0 Hz to 50 MHz	
Phase modulation		
Waveform	Sine, dual-sine, triangle, ramp up, ramp down, square	
PM rate	Sine	1 Hz to (maximum baseband bandwidth / 4) ^{Error!} Bookmark not defined.
	All other waveforms	1 Hz to (maximum baseband bandwidth / 16) ^{Error!} Bookmark not defined.
PM depth	0 to 10 radians	

²³ See **RF (I + Q) bandwidth and sample rate** for available modulation bandwidth.

Vector Modulation Specifications

Internal I/Q baseband generator adjustments ²⁴

Internal I/Q offset	Separate I and Q offsets, $\pm 20\%$
Internal I/Q quadrature angle	$\pm 20^\circ$
Internal I/Q gain balance	± 10 dB
Internal I/Q time skew	± 83.3333 ns
I/Q common delay range	0 to 41.6667 ns
I/Q common delay resolution	250 fs

Carrier leakage

None (direct digital modulation, no I/Q modulator)

Frequency response over available modulation bandwidth²⁵, measured

Frequency range	Amplitude	Phase
400 MHz to 8.5 GHz	± 0.6 dB	$\pm 5^\circ$

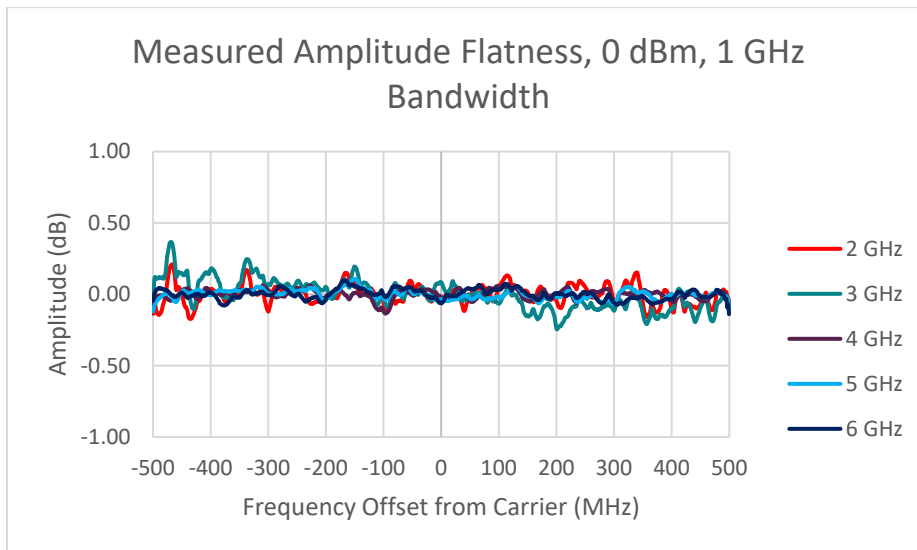

²⁴ I/Q adjustments represent user interface nominal parameter ranges and not specifications.

²⁵ See [RF \(I + Q\) bandwidth and sample rate](#) for available modulation bandwidth.

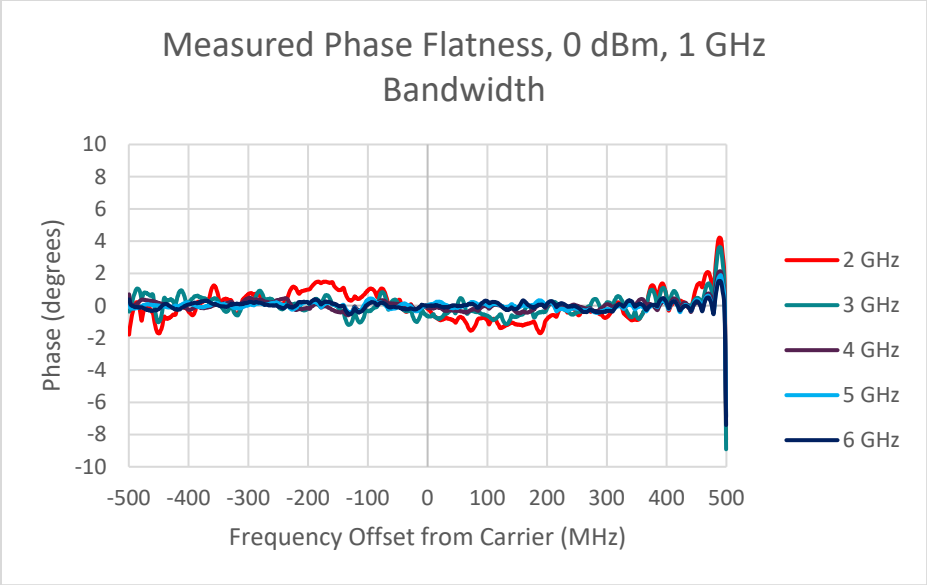

User defined automatic channel response correction and S-parameter de-embedding (E7653APPC)

Methods for fixture error removal	
Scatter parameters de-embedding/embedding files generated by a network analyzer or simulation	
Automatic channel response correction using a power sensor or spectrum analyzer (amplitude and phase correction)	
Scalar user flatness (absolute power correction)	
Scatter parameters	
File format	.s2p, .csv
Number of cascadable calibration sets	4
Automated channel response correction (256 taps) ²⁶	
Recommended maximum amplitude for error correction	± 5 dB across modulation bandwidth
User flatness	
File format	.uflat, .csv
Entry modes	USB or LAN direct power meter control

²⁶ Automated routine uses power sensor to correct for linear amplitude response of DUT (equalizer). See User Documentation for more details.

Internal Baseband Generator (Options BxX / Rxx)

Definitions

Channel or port	The number of physical RF outputs
Signal	Each channel can generate one signal (ex: one waveform file).

Internal baseband generator (Options BxX / Rxx)

I/Q file resolution	16 bits
Waveform granularity	1 sample
Frequency offset	+/- half maximum bandwidth
Signal attenuation	0 to -100 dB
Sample rate resolution	1 Hz
Interpolated I/Q rate	1.2 GHz

RF (I + Q) bandwidth ²⁷ and sample rate

Option	RF (I + Q) bandwidth (nom)	Sample rate (nom)
Option B2X	250 MHz	312.5 MHz
Option B5X	500 MHz	625 MHz
Option B9X / R10 ²⁸	1 GHz	1.2 GHz

Arbitrary waveform memory

Maximum arbitrary waveform playback memory	Standard	256 MSa
	Option M05	512 MSa
	Option M10	1024 MSa
	Option M20	2048 MSa
Maximum storage capacity	256 GB (nom)	

Waveform segments

Segment length	Minimum: 128
	Maximum: See Maximum arbitrary waveform playback memory
	Quantum: See Waveform granularity
Minimum memory allocation blocking factor	64 Bytes or 16 samples
Maximum number of waveform files	> 1000, depending on available memory

Waveform sequences

Maximum number of segments per sequences	65,280
Maximum number of repetitions	2 ³² -1

²⁷ Lower edge of modulated signal is not recommended to extend below 10 MHz. Upper edge of modulated signal is not recommended to extend above 8.5 GHz.

²⁸ 1 GHz RF bandwidth applies to Option B9X with firmware version A.16.00 or later.

Triggers

Types	Continuous, single, gated, segment advance	
Source	Trigger key, external, bus (GPIO, LAN, USB) Global trigger (Option PCH)	
Modes	Continuous	Free run, trigger and run, reset and run
	Single	Buffered trigger, no retrigger, restart on trigger
	Gated	Negative polarity or positive polarity
	Segment advance	Not supported
External delay time	0 to 41s (nom)	
External delay resolution	833 ps (nom)	
I/Q delay range	See Internal I/Q baseband generator adjustments section	
I/Q delay resolution	See Internal I/Q baseband generator adjustments section	

Multi-channel baseband synchronization primary/secondary (Option PCH and SNC)

Global trigger delay range	0 μ s to 6.82 μ s
Global trigger delay resolution	\pm 1.67 ns
Global trigger jitter	\pm 1.67 ns
Channel-to-channel relative trigger repeatability	$<$ \pm 5 ps

Markers

Markers are defined in a segment during the waveform generation process, or from the front panel; see [User Documentation](#) or [Online Help](#) for more information.

Marker polarity	Positive, negative
Number of markers	3

AWGN (Option 403)

Type	Real-time
Modes of operation	Standalone signal or digitally added to signals
Crest factor	12.9 dB (nom)
Randomness	16.3 hours (nom)
Carrier-to-noise ratio	\pm 100 dB when added to signal
Carrier-to-noise ratio formats	C/N, Eb/No

CW interferer (Option 403)

Type	Real-time
Modes of operation	Standalone signal or digitally added to signals
Power control	Absolute, relative to signal power
Frequency offset	\pm half of maximum baseband bandwidth ²⁹

²⁹ For maximum baseband bandwidth and sample rate, see [RF \(I + Q\) bandwidth and sample rate](#).

Multitone and single tone (E7621APPC)

Type	Arbitrary waveform file	
Number of tones	Multitone mode	2 to 200,001
	Single tone mode ³⁰	1
Tone spacing	100 Hz to Floor $[(\text{maximum baseband bandwidth}^{31})/((\text{number of tones} - 1)/100)] * 100$	
Phase (per tone)	Random, fixed (remote command only)	

Multi-Instrument Synchronization (Option SNC)

Multi-instrument synchronization mechanism ³²

Number of endpoints	Up to 4
Instrument configuration	Any configuration combination
Operating modes	With leader, independent

Multi-instrument synchronization configurations ³²

The leader instrument must be able to supply the required inputs to each follower. For configurations where the number of required follower inputs exceeds the available leader outputs, a power splitter or distribution amplifier may be required. See Startup Guide for input/output power level requirements. An endpoint is defined as a single N5186A instrument, regardless of channels in the instrument.

Number of Channels	Hardware Configuration		Basic multi-instrument synchronization	
			Number of available outputs as a leader	Number of available inputs as a follower
	Maximum frequency	Endpoints	2.4 GHz	2.4 GHz
1 (Opt. 001)	3, 6, or 8.5 GHz	1	1	1
2 (Opt. 001 and 002)		1	1	1
4 (Opt. 001, 002, 003, and 004)		1	1	1

³⁰ Single tone generates a single CW tone at a specified offset to the channel's RF frequency.

³¹ For maximum baseband bandwidth and sample rate, see [RF \(I + Q\) bandwidth and sample rate](#).

³² Compatible with serial prefix breaks MY6436xxxx or higher.

Error Vector Magnitude (EVM)

EVM performance data ³³, temperature range 20 to 30 °C

Format	GSM	LTE FDD	802.11a/g	802.11ac	QPSK		16QAM		
Modulation type	GMSK (burst)	64 QAM	64 QAM	256 QAM	QPSK		16 QAM		
Modulation rate	270.833 ksps	10 MHz BW	54 Mbps	80 MHz	4 Msps (root-Nyquist filter $\alpha = 0.25$)				
Configuration	1 timeslot	E-TM 3.1	-	-	-		-		
Frequency ³⁴	800 to 900 MHz 1800 to 1900 MHz	1800 to 2200 MHz	2400 to 2484 MHz 5150 to 5825 MHz	5.775 GHz	≤ 3 GHz	≤ 6 GHz	≤ 3 GHz	≤ 6 GHz	
Power level	-10 dBm to +7 dBm	-20 dBm to +7 dBm	-18 dBm to -5 dBm	-15 dBm to -5 dBm	-20 dBm to +4 dBm		-20 dBm to +4 dBm		
Power level with option 1EA	-10 dBm to +10 dBm	-20 dBm to +10 dBm	-18 dBm to +2 dBm	-15 dBm to +2 dBm	-20 dBm to +10 dBm		-20 dBm to +10 dBm		
EVM / global phase error	Spec	Typ	Typ	Meas	Meas	Spec	Spec	Spec	Spec
	rms 0.8°	0.2°	0.2%	0.2%	0.36%	0.8%	1.1%	0.65%	0.9%

EVM for 5G NR FR1 bands, -10 dBm to +5 dBm, () = typical

Frequency	100 MHz, 256 QAM, 60 kHz SCS, NRB = 135
2 GHz	(0.25%)
3.55 GHz	(0.27%)
4.5 GHz	(0.29%)

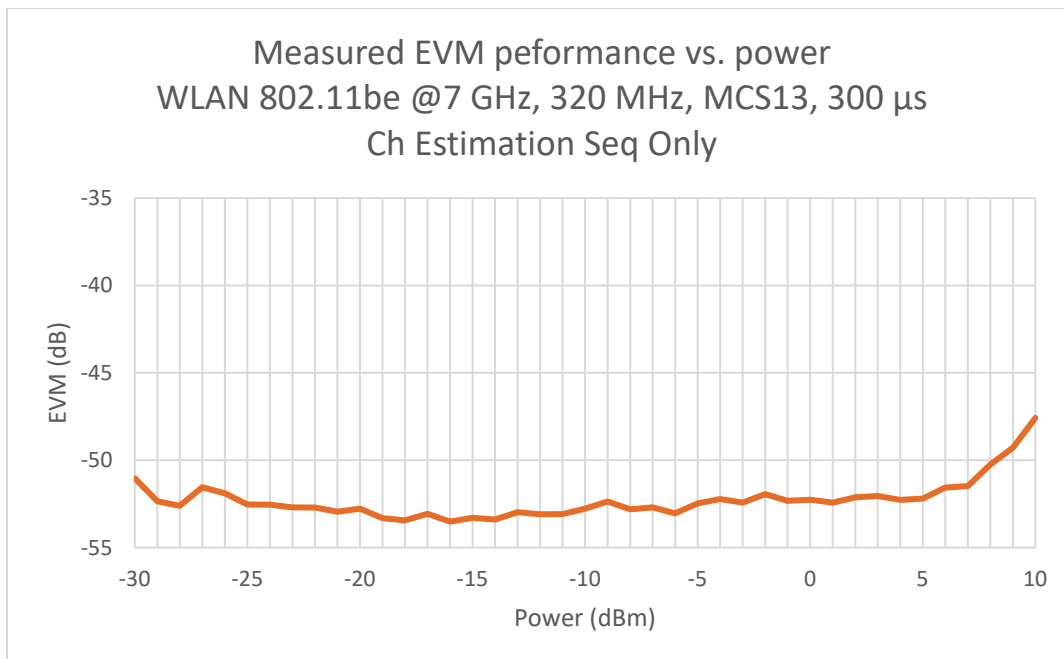

³³ EVM specifications apply for the default ARB file setup conditions with the default ARB files supplied with the instrument.

³⁴ Performance evaluated at bottom, middle, and top of bands shown. WLAN 802.11ac 80 MHz, 256 QAM, MCS 8, 7 symbols, no filtering. Channel corrections.

Distortion Performance (ACPR)

3GPP W-CDMA distortion performance, temperature range 20 to 30 °C, () = typical

Power level			-12 dBm to +2 dBm ³⁵	-12 dBm to + 2 dBm ¹⁹	-12 dBm to +5 dBm ¹⁹
Offset	Configuration	Frequency	Standard	Option UNV	Option UNV with option 1EA
Adjacent (5 MHz)	1 DPCH, 1 carrier	1800 to 2200 MHz	(-71 dBc)	(-73 dBc)	(-73 dBc)
Alternate (10 MHz)			(-72 dBc)	(-74 dBc)	(-74 dBc)
Adjacent (5 MHz)	Test model 1 with 64 DPCH, 1 carrier	1800 to 2200 MHz	(-70 dBc)	(-72 dBc)	(-72 dBc)
Alternate (10 MHz)			(-71 dBc)	(-73 dBc)	(-73 dBc)

3GPP LTE-FDD distortion performance, temperature range 20 to 30 °C, () = typical

Power level			-10 dBm to +2 dBm	-10 dBm to +2 dBm	-10 dBm to +5 dBm
Offset ³⁶	Configuration	Frequency	Standard	Option UNV	Option UNV with option 1EA
Adjacent (10 MHz)	10 MHz E-TM 1.1 QPSK	1800 to 2200 MHz	-64 dBc	-67 dBc (-69 dBc)	-67 dBc (-69 dBc)
Alternate (20 MHz)			-66 dBc	-69 dBc (-71 dBc)	-69 dBc (-71 dBc)

GSM output RF spectrum (ORFS) distortion performance, temperature range 20 to 30 °C, () = typical

Power level			-10 dBm to +7 dBm	
Offset	Configuration	Frequency ³⁷	Standard	Option UNV
200 kHz	1 normal timeslot, bursted	800 to 900 MHz 1800 to 1900 MHz	(-34 dBc)	(-36 dBc)
400 kHz			(-69 dBc)	(-71 dBc)
600 kHz			(-81 dBc)	(-86 dBc)
800 kHz			(-82 dBc)	(-84 dBc)
1200 kHz			(-84 dBc)	(-88 dBc)

5G NR FR1 bands distortion performance, -10 dBm to +5 dBm, temperature range 20 to 30 °C, () = typical

Offset	Configuration	Frequency	Standard
Adjacent (100 MHz)	100 MHz, 256 QAM, 60 kHz SCS, NRB =135	2 GHz	-58 dBc
Alternate (200 MHz)			-59 dBc
Adjacent (100 MHz)		3.55 GHz	-58 dBc
Alternate (200 MHz)			-55 dBc
Adjacent (100 MHz)		4.5 GHz	-55 dBc
Alternate (200 MHz)			-57 dBc
Adjacent (100 MHz)		5 GHz	-56 dBc
Alternate (200 MHz)			-56 dBc

³⁵ This is rms power. Convert from rms to peak envelope power with the following equation: PEP = rms power + crest factor (for example, 3GPP test model 1 with 64 DPCH has a crest factor 11.5 dB, therefore at +5 dBm rms, the PEP = 5 dBm + 11.5 dB = +16.5 dBm PEP).

³⁶ ACPR measurement configuration: reference channel integration BW: 9.015 MHz, offset channel integration BW: 9.015 MHz.

³⁷ Performance evaluated at bottom, middle, and top of bands shown.

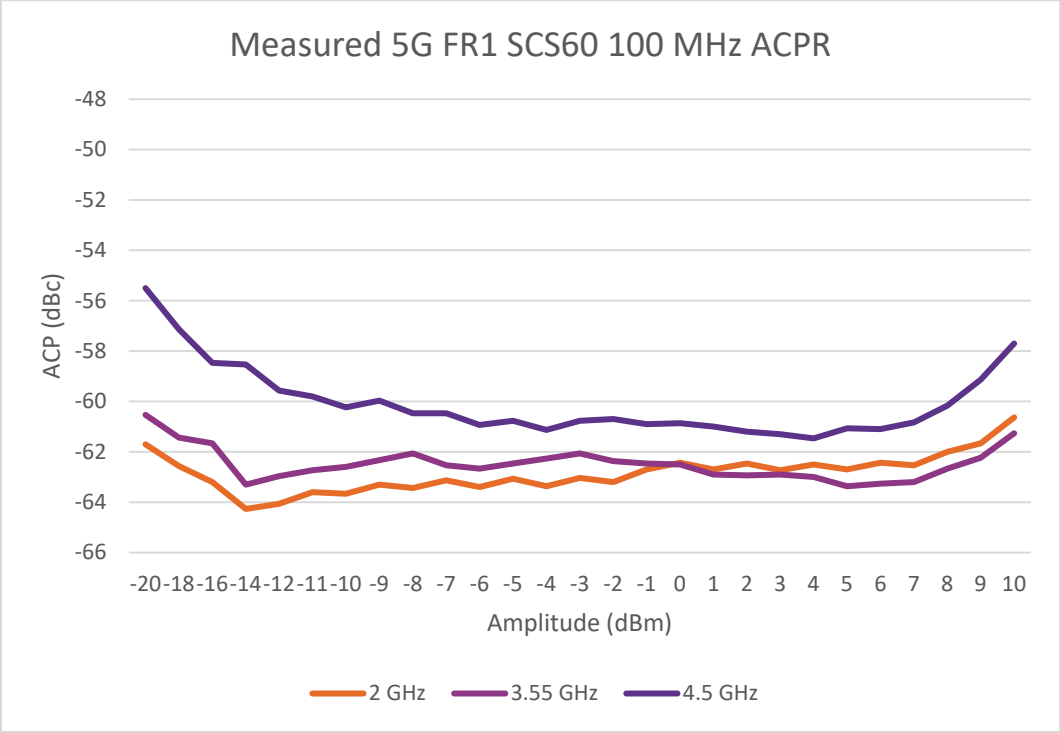
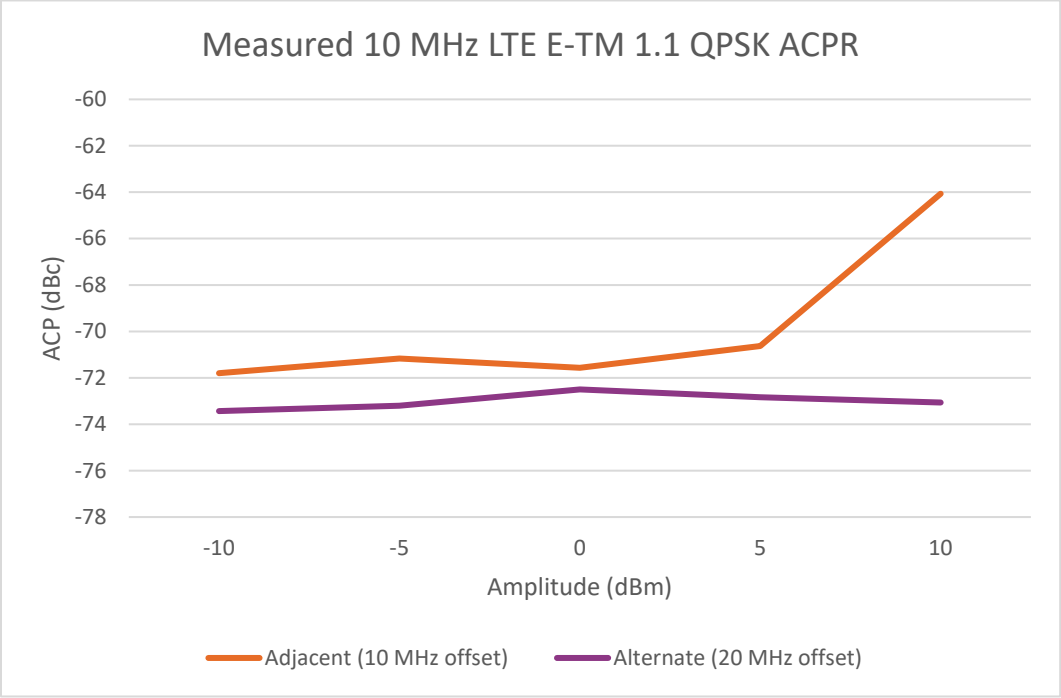

Inputs and Outputs

Front panel connectors

RF output	Outputs the RF signal via a precision Type-N female connector; see output section for reverse power protection information
USB 2.0	Type-A connector used with a memory stick for transferring instrument states, licenses and other files into or out of the instrument.
USB 3.0	Outputs 2 A at 15 V.

Rear panel connectors

Rear panel inputs and outputs are 3.3 V CMOS, unless indicated otherwise; CMOS inputs will accept 5 V CMOS, 3 V CMOS, or TTL voltage levels.		
RF output (Option 1EM)	1 channel configuration	Outputs the RF signal via a precision Type-N female connector
	2 channel configuration	Outputs the RF signal via a precision Type-N female connector
	4 channel configuration	Outputs the RF signal via a 3.5 mm female connector
EXT1 In	BNC connector accepts analog input signal for AM, FM, and Φ M. Selectable 50 Ω , 600 Ω , 100 k Ω nominal input impedance. Selectable DC- or AC- coupling. Damage levels are ± 5 V.	
EXT2 In	BNC connector accepts analog input signal for AM, FM, and Φ M. Selectable 50 Ω , 600 Ω , 100 k Ω nominal input impedance. Selectable DC- or AC- coupling. Damage levels are ± 5 V.	
Event 1-3	Channel 1	BNC connector. The marker signal can also be routed internally to control the RF blanking.
	Channels 2-4	SMB connector; only events 1-2. The marker signal can also be routed internally to control the RF blanking.
Trigger 1-5 / STRig In	Channel 1	BNC connector. Accepts CMOS signal with minimum pulse width of 10 ns. Damage levels are $> +5.5$ V and < -2 V.
	Channels 2-4	SMB connector, only triggers 1-5. Accepts CMOS signal with minimum pulse width of 10 ns. Damage levels are $> +5.5$ V and < -2 V.
Pulse In	Channel 1	BNC connector; see Internal Pulse Generator table for more information. Input threshold 0.5 V nominal. Damage levels are $> +5$ V and < -4.5 V.
	Channels 2-4	SMB connector; see Internal Pulse Generator table for more information. Input threshold 0.5 V nominal. Damage levels are $> +5$ V and < -4.5 V.
LF OUT / SWEEP OUT	BNC connector outputs the internal analog modulation source signal. -1V to +5V nominal output into 50 Ω . Nominal 50 Ω output impedance.	
Reference input	BNC connector; accepts a 10 MHz reference signal used to frequency lock the internal timebase. Input damage level is +16 dBm. Option 1ER add the capability to lock to a frequency from 1 MHz to 110 MHz; nominal input level -3 to +20 dBm, impedance 50 Ω , sine or square waveform.	
10 MHz out (Ref Out)	BNC connectors outputs the 10 MHz reference signal used by internal timebase; level nominally +3.9 dBm; nominal output impedance 50 Ω .	
USB	Type-A	Copy files to and from removable storage devices.
	Type-B	Provides remote programming functions via SCPI over USBTMC/USB488.
LAN (1000 BaseT)	The LAN connector provides the same SCPI remote programming functionality as the GPIB connector and is also used to access the internal Web server and FTP server. Supports DHCP, sockets SCPI, VXI-11 SCPI, connection monitoring, dynamic hostname services, TCP keep alive. LXI class C compliant	
GPIB	The micro GPIB connector provides remote programming functionality via SCPI.	

Remote Programming

Remote programming

Interfaces	VXI-11 HiSlip SOCKET USB-488 GPIB USB Version-488
Control languages	Control languages SCPI Version 1997.0
Keysight IO libraries	Keysight's IO Library Suite helps you quickly establish an error-free connection between your PC and instruments – regardless of the vendor. It provides robust instrument control and works with the software development environment you choose.

General Specifications

Environmental specifications and regulatory compliance

Temperature	Operating	1 channel	0 to 55 °C
		2 channel	0 to 50 °C
		4 channel	0 to 50 °C
	Storage	-40 to +70 °C	
Maximum relative humidity (non-condensing)	95%RH up to 40 °C, decreases linearly to 45%RH at 55 °C		
Operating and storage altitude	Up to 4,600 meters		
Indoor use	For indoor use only		
Environmental testing	Samples of this product have been type tested in accordance with the Keysight Environmental Test Manual and verified to be robust against the environmental stresses of storage, transportation and enduse; those stresses include but are not limited to temperature, humidity, shock, vibration, altitude, and power line conditions; test methods are aligned with IEC 60068-2 and levels are similar to MILPRF28800F Class 3		
Safety	Complies with European Low Voltage Directive 2006/95/EC	IEC/EN 61010-1 ³⁸ Canada: CSA C22.2 No. 61010-1 USA: UL std no. 61010-1 German Acoustic statement	
		Acoustic noise emission LpA < 77.5 dB Operator position Normal position Per ISO 7779	
	Complies with European EMC Directive 2004/108/EC	Geraeuschemission LpA < 77.5 dB Am Arbeitsplatz Normaler Betrieb Nach DIN 45635 t.19	
		IEC/EN 61326-1or IEC/EN 61326-2-1 CISPR Pub 11 Group 1, class A AS/NZS CISPR 11 ICES/NMB-001 2This ISM device complies with Canadian ICES-001. Cet appareil ISM est conforme a la norme NMB-001 du Canada.	

³⁸ AC line voltage dropouts (IEC 61000-4-11) of duration greater than 5 ms will cause the RF output to turn off until it is re-enabled by the operator, in order to protect internal hardware.

Power requirements

Number of channels	Maximum frequency	Power requirements	Average power consumption
1 (opt. 001)	3/6/8.5 GHz (opt. 503/506/508)	100/120 VAC, 50/60/400 Hz 220/240 VAC, 50/60/400 Hz 650 W Max	270 W nom.
2 (opt. 001, 002)	3/6/8.5 GHz (opt. 503/506/508)	100/120 VAC, 50/60/400 Hz 220/240 VAC, 50/60/400 Hz 650 W Max	380 W nom.
4 (opt. 001, 002, 003, and 004)	3/6/8.5 GHz (opt. 503/506/508)	100/120 VAC, 50/60/400 Hz 220/240 VAC, 50/60/400 Hz 650 W Max	550 W nom.

Physical specifications

Configuration		1 channel (001)	2 channel (001/002)	4 channel (001/002/003/004)
Weight		16.09 kg (or 35.47 lbs)	17.9 kg (39.46 lbs)	21.73 kg (or 47.91 lbs)
Dimensions	Height	88.25 mm (without feet)		
		102 mm (with feet)		
	Width with handles	474.7 mm		
	Width without handles	425.5 mm		
	Length with handles (including connectors)	591.1 mm		
Display	Resolution	1280 x 400		
	Size	190.08 mm x 59.44 mm		

Data storage

Internal	Removable solid-state drive (256 GB)
External	Supports USB 3.0/2.0 compatible memory devices

Self-test

Internal diagnostic routines test most modules in a preset condition; for each module, if its node voltages are within acceptable limits, the module passes the test.

Recommended calibration cycle

1 year

KeysightCare Coverage

One year of KeysightCare Assured is included with your new N5186A MXG Vector Signal Generator for priority access to technical experts and optimized uptime to mitigate project risk. Multiyear upgrade options to KeysightCare Enhanced add calibration coverage for full performance verification and accelerated turnaround times.

Obtain multi-year KeysightCare upfront to lock in the service pricing of today and operate with a planned spending profile and eliminate the need for yearly requests for maintenance budget. Plus, you benefit from secured service for 2, 3, or 5 years.

Service	Function
KeysightCare Enhanced ³⁹	Includes tech support, warranty, and calibration
R-55B-001-1	KeysightCare Enhanced – Upgrade 1 year
R-55B-001-2	KeysightCare Enhanced – Extend to 2 years
R-55B-001-3	KeysightCare Enhanced – Extend to 3 years (Recommended)
R-55B-001-5	KeysightCare Enhanced – Extend to 5 years (Recommended)
R-55B-001-3CC	KeysightCare Enhanced – Extend to 3 years (China only) ⁴⁰
R-55B-001-5CJ	KeysightCare Enhanced – Extend to 5 years (Japan only)
KeysightCare Assured	Includes tech support and warranty
R-55A-001-2	KeysightCare Assured – Extend to 2 years
R-55A-001-3	KeysightCare Assured – Extend to 3 years
R-55A-001-5	KeysightCare Assured – Extend to 5 years
R-55A-001-3CC	KeysightCare Assured – Extend to 3 years (China only)
R-55A-001-5CC	KeysightCare Assured – Extend to 5 years (China only)
R-55A-001-5CJ	KeysightCare Assured – Extend to 5 years (Japan only)
Start-Up Assistance	
PS-S20	Startup assistance, daily
PS-X10	Custom Services

³⁹ Available in select countries. R-55B-001-2/3/5 must be ordered with R-55B-001-1. For details, please view the KeysightCare [datasheet](#).

⁴⁰ Contact Keysight for 5 year coverage.

Related Literature

Publication title	Publication number
N5186A MXG Configuration Guide	3123-1623EN

Keysight enables innovators to push the boundaries of engineering by quickly solving design, emulation, and test challenges to create the best product experiences. Start your innovation journey at www.keysight.com.



This information is subject to change without notice. © Keysight Technologies, 2023 - 2026, Published in USA, February 26, 2026, 3123-1690.EN